

BOSCH

July 1998
INDUSTRIAL

3/8" DRILL
Model 0601144562

1005VSR

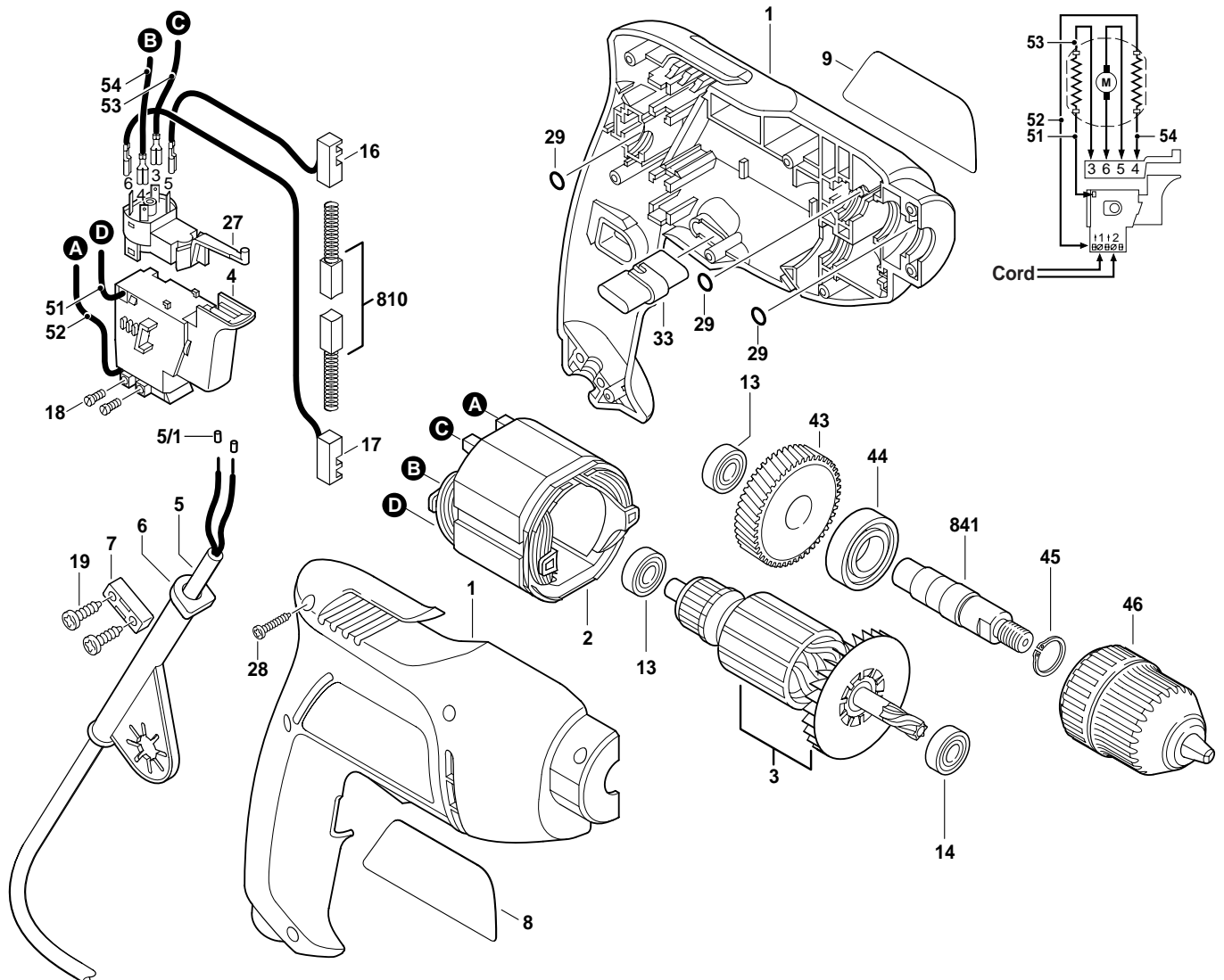

Pos.	Part Number	Description {Qty}	F/C	Pos.	Part Number	Description {Qty}	F/C
1	2 605 104 590	Housing Assembly	71	19	2 910 611 019	Screw {2}	89
2	2 604 220 626	Field 120V	22	27	2 607 200 399	Reversing Switch	16
3	2 604 011 204	Armature w/Fan120V	AW	28	2 603 435 065	Screw {8}	89
4	2 607 200 406	Switch VS 120V	17	29	2 600 210 036	O-Ring {3}	78
5	3 604 460 555	Cord 120V 18/2	11	33	2 609 100 002	Lever	64
5/1	1 900 452 012	Terminal Sleeve {2}	11	43	2 609 110 045	Gear	33
6	2 600 707 060	Strain Relief	11	44	1 900 905 122	Ball Bearing	56
7	2 601 035 001	Cord Clamp	89	45	2 916 650 006	Retaining Ring	89
8	2 609 130 133	Nameplate	9	46	2 610 910 300	3/8" Keyless Chuck	91
9	2 609 130 109	Label "1005VSR"	9	51	2 604 448 212	Cable	10
13	2 600 905 046	Ball Bearing {2}	51	52	2 604 448 080	Cable	10
14	2 609 110 054	Ball Bearing	61	53	2 609 120 004	Cable	10
16	2 604 449 050	Brush Holder	25	54	2 609 120 005	Cable	10
17	2 604 449 051	Brush Holder	25	810	2 604 321 904	Brush Set	26
18	2 603 410 001	Screw {2}	89	841	2 609 110 026	Spindle 3/8"- 24	52

+ = Not Illustrated * = As Required F/C = Failure Code AW = Refer to AW Labor Time Chart

S-B Power Tool Company Chicago IL 60646-5999